

# ***Quick Coupling Diagnostic Products***

F Diagnostic



Increasing productivity and profitability are the key elements for a company to successfully compete in the world market today.

Reduced machine downtime during initial set-up, trouble shooting and maintenance procedures means increased productivity for you. That's why Parker provides the most complete line of hydraulic and pneumatic diagnostic equipment available today.

With Parker diagnostic equipment you can take critical measurements from your system with just a push of a button. Parker diagnostic instruments are designed to identify hard-to detect variations and peaks in pressures, temperatures and flow.

Parker diagnostic quick couplings and nipples allow quick

and easy access into hydraulic or pneumatic systems at remote test points without the use of tools.

Diagnostic nipples can be permanently installed in threaded test ports in hydraulic components such as valves, cylinders, accumulators, filters or pumps.

Diagnostic tube ends, used in conjunction with a 37° flare, bite type, or O-ring face seal tube fitting, will allow you to take pressure readings in your systems tubing and hose lines where threaded test ports may not currently be available.

From diagnostic nipples to digital readout and printing equipment, Parker can provide you, from over 600 stocking distributors, the tools necessary to increase your productivity through reduced machine downtime.

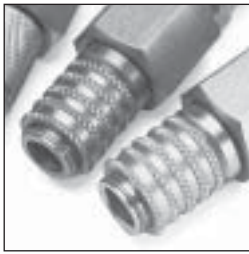

**Introduction .....F-2**

**Table of Contents.....F-3**

**Product Selection Guide.....F-4**

**ServiceJunior™ .....F-5**

**SensoControl® Serviceman™**

    General .....F-6

    Schematic.....F-7

    Technical Data .....F-8

    Test Meter Kits .....F-9

    Components and Accessories.....F-14 - F-17

**SensoControl® Service Master**

    General .....F-10

    Schematic.....F-11

    Technical Data .....F-12

    Test Meter Kits .....F-13

    Components and Accessories.....F-14 - F-17

**PDF Series Flow Sensors .....F-15**

**Test Port Couplings**

PD Series.....F-18 - F-20

    Dust Cap.....F-18

    Couplers .....F-19

    Nipples .....F-19 - F-20

    Tube End Nipples .....F-20

PDP Series .....F-21 - F-23

    Dust Cap.....F-21

    Couplers .....F-21

    Nipples.....F-22

EMA3 Series.....F-23

    Nipples.....F-23

    Gauge Adapter & Union .....F-24

Transducer Adapters.....F-25

Flexible Hose .....F-25

PDFS Series - Fluid Sampling.....F-26

    Couplers .....F-26

    Nipples.....F-26

Ordering Information.....F-27

Diagnostic Products

Meter Selection Guide

Function	ServiceJunior	Serviceman	Service Master 360	Service Master 450
Pressure Sensing	•	•	•	•
Flow Sensing		•1	•1	•1
Temperature Sensing		•1	•2	•2
Rotational Speed Sensing		•1	•	•
Auxiliary Sensing			•	•
Pressure Differential		•	•	•
Automatic Sensor Recognition	•	•	•	•
Auto Power Off	•	•	•	•
Battery Monitoring	•	•	•	•
Battery Type	AA (2 req'd)	Rechargeable Ni-MH	Rechargeable Ni-Cad	Rechargeable Ni-Cad
PC Compatible (Windows)		•1	•1	•1
Minimum/Maximum Memory	•	•	•	•
Self Contained Memory			•	•
On-Line Data Transfer		•	•	•
Text Display (Lines)	2	2	8	8
Inputs	1	2	4	6
Data Points (Maximum in Memory)			125,000	250,000
Graphic LCD Display	•		•	•
Hydraulic Power Calculations			•	•
Volume Calculations			•	•

Notes: (1) Additional accessories are required to perform this function.  
 (2) Transducers provide an ambient temperature signal, but additional temperature probes are required for more accurate temperature measurements.

Test Port Coupling Selection Guide

	Valving	Body Size	Material* Br SS S P	Locking Mechanism	Std. Seal Material	Temp Range**	Rated Pressure
<b>Test Port</b>							
PD Series	Flush Face	1/8"	• • •	Ball	Nitrile	-40° to +250° F	6000 PSI
PDP Series	Ball	1/8"	• • •	Ball	Nitrile	-40° to +250° F	6000 PSI
EMA3 Series	Poppet	1/8"	• •	Threads	Nitrile	-15° to +250° F	9000 PSI

\* See Fluid Compatibility chart and/or consult factory for questions regarding proper material for specific applications.  
 CODE: Br = Brass; SS = Stainless Steel; S = Steel; P = Plastic  
 \*\*Temperature Range for standard seal material.

Note: See the Specifications Table for PD and PDP Series for more information.



F Diagnostic

The new Parker ServiceJunior captures momentary pressure spikes that are “invisible” to normal liquid-filled gauges. That means the maximum pressure reading it delivers can be trusted as a much truer reflection of the system’s actual condition; so you can identify potential problems better and diagnose their causes faster. All readings are accurate to within +/-0.5%.

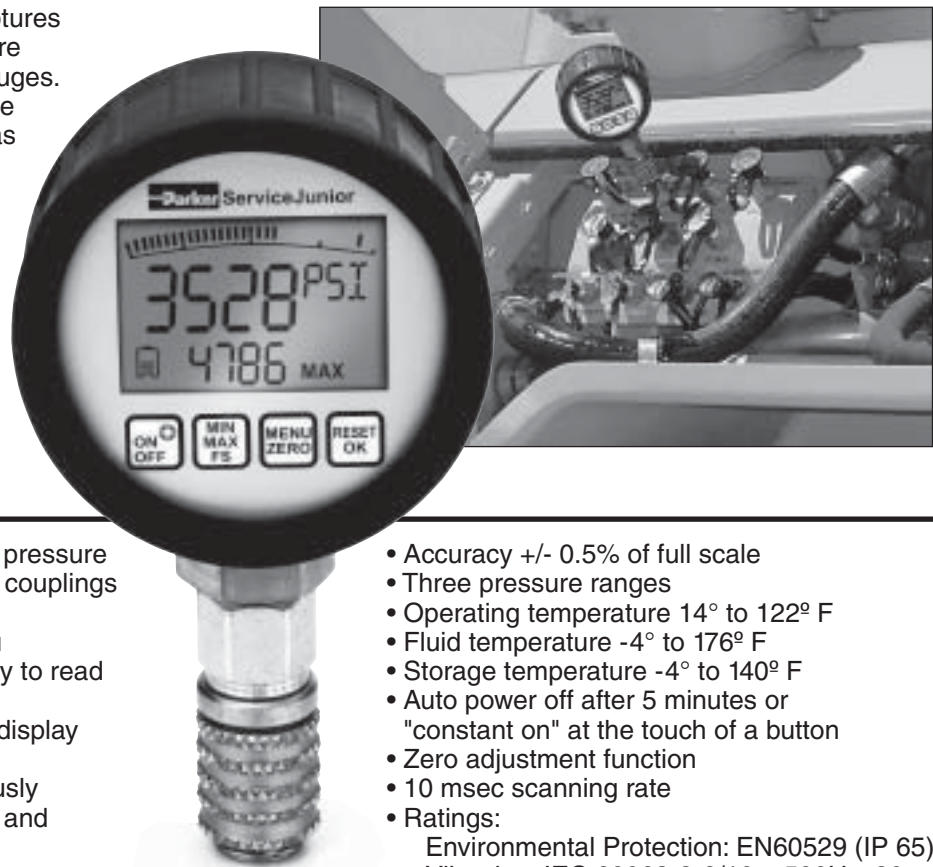

**ServiceJunior Features**

- Easy to connect and test system pressure using Parker Diagnostic test port couplings
- Robust, dirt resistant housing
- Simple to operate, four key menu
- Four digit backlit display with easy to read large 0.60" characters
- Minimum and maximum graphic display shows pressure peak
- Power status displayed continuously
- Can be used with most hydraulic and pneumatic media
- Measure PSI, bar, mPa, kPa with one gauge

- Accuracy +/- 0.5% of full scale
- Three pressure ranges
- Operating temperature 14° to 122° F
- Fluid temperature -4° to 176° F
- Storage temperature -4° to 140° F
- Auto power off after 5 minutes or "constant on" at the touch of a button
- Zero adjustment function
- 10 msec scanning rate
- Ratings:  
Environmental Protection: EN60529 (IP 65)  
Vibration: IEC 60068-2-6/10 – 500Hz: 20g  
Shock: IEC 60068-2-29/50g 11 msec

Measuring Range	ServiceJunior with PD Coupler	ServiceJunior with EMA3 Coupler	ServiceJunior with 1/4" NPT Port	Overload Pressure	Resolution
-14.5 to 250 PSI (-1 to 16 bar)	SCJR-0250-PD	SCJR-0250-EMA	SCJR-0250-4MP	580 PSI	0.1 PSI
0 to 5800 PSI (0 to 400 bar)	SCJR-5800-PD	SCJR-5800-EMA	SCJR-5800-4MP	11,600 PSI	1 PSI
0 to 8700 PSI (0 to 600 bar)	SCJR-8700-PD <sup>1</sup>	SCJR-8700-EMA <sup>2</sup>	SCJR-8700-4MP	17,400 PSI	1 PSI

NOTES: 1. PD Couplers rated to 6,000 PSI max. 2. EMA3 Couplers rated to 9,000 PSI max.

**Accessories**

Part Number	Description
PD240	PD Series diagnostic coupler
SCA-7/16-EMA-3	7/16 -18UNF-2B female to M16X2.0 EMA3 female swivel
SCJA-1/4	7/16 -18UNF-2B female to 1/4" NPT male adapter
PDH-19	19" PD Hose extension to be used with PD nipple interface
SMA3-400	16" hose assembly for EMA M16X2.0 interface
SCC-110	Storage case for one gauge and diagnostic adapters
SCC-120	Storage case for two gauges and diagnostic adapters



**Hand-held Diagnostic Meter to Measure Pressure, Temperature, Flow and Rotational Speed for Hydraulic and Pneumatic Systems**

- Easy operation
- Rugged design
- Compact Dimensions
- Two line display
- Auto sensor recognition
- MIN/MAX Memory
- Pressure differential
- External power supply
- Data output for PC



The Serviceman SCM-152 from Parker is a portable diagnostic measuring system – an excellent alternative to conventional mechanical pressure gages – a very rugged, durable test meter that can withstand even the most demanding environmental conditions.

The Serviceman meter uses the latest in sensor recognition technology which eliminates the need for meter adjustment. It's powered by a rechargeable Ni-MH battery system or a 120 volt external power supply for continuous operation

Using Serviceman software (compatible with Windows 98 and newer operating systems) the SCM-152 quickly interfaces with an Excel spread sheet.

The Serviceman field kit is the ideal set of diagnostic tools for maintenance and service personnel in the industrial, mobile and agricultural markets. These units help reduce downtime by recording the best preventative maintenance and diagnostic data available.

Parker Hannifin provides the most complete line of hydraulic and pneumatic diagnostic equipment available today. For more information contact the Quick Coupling Division or your local distributor.

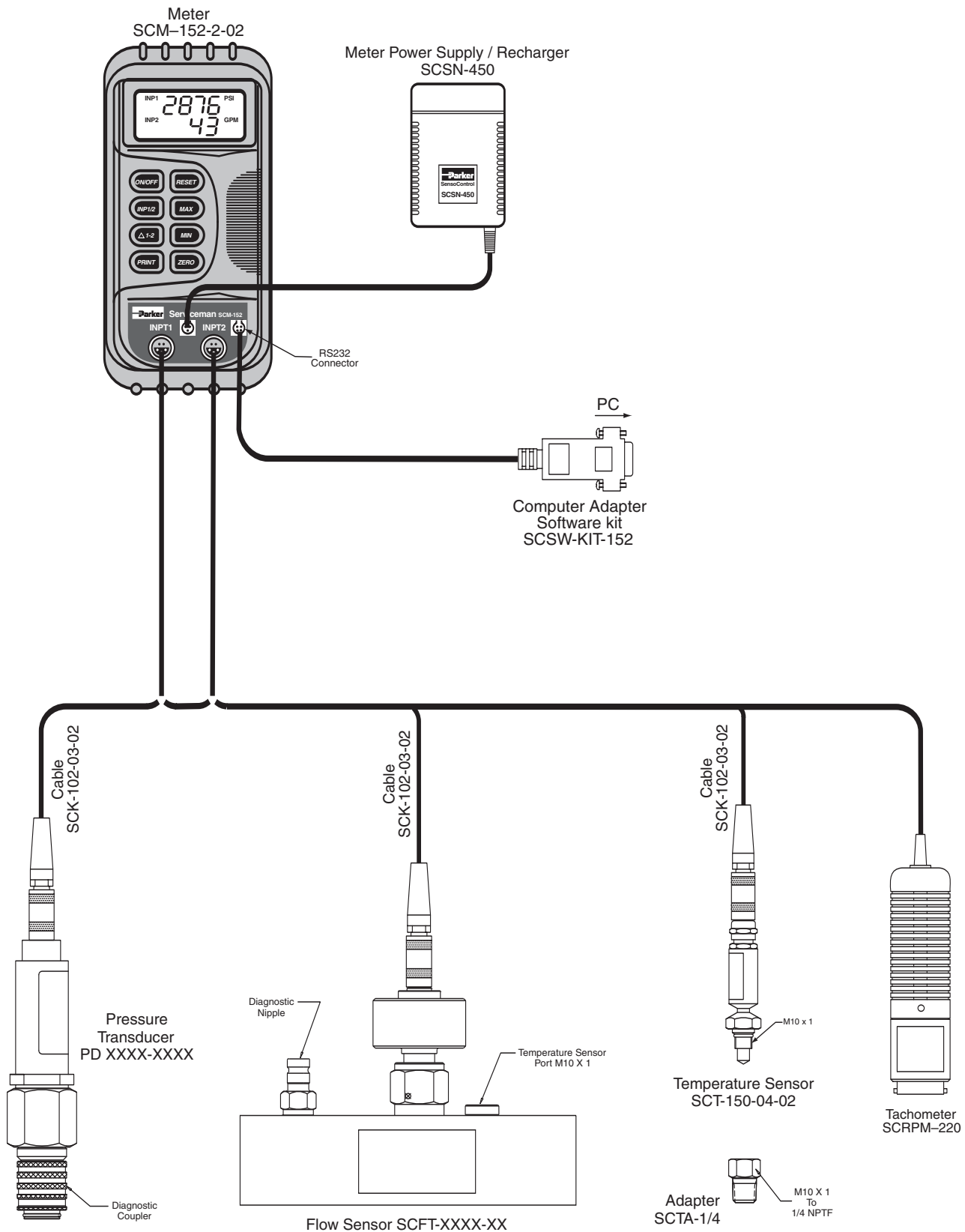

F Diagnostic

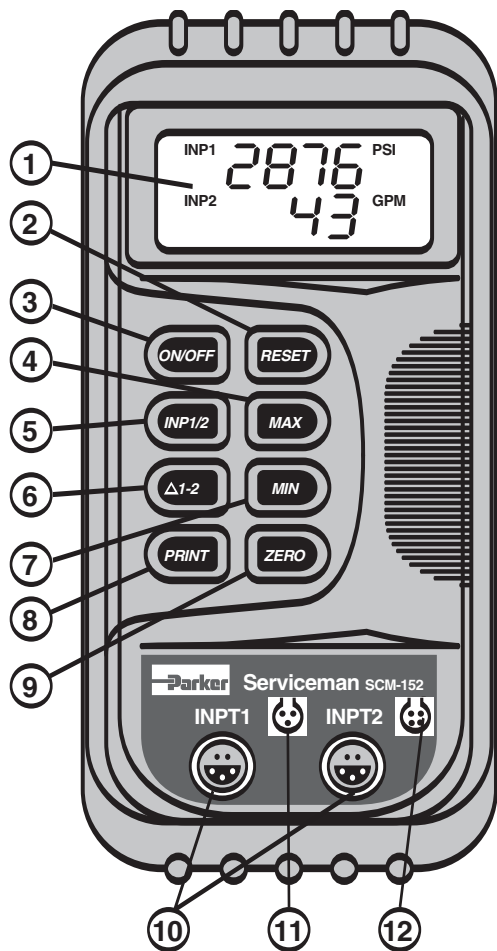

**Function Descriptions**

- 1 **Two Line Measurement Display**
- 2 **RESET** resets minimum and maximum values to zero
- 3 **ON/OFF** Switch
- 4 **MAX** displays maximum value since meter was last reset or turned on
- 5 **INP1/2** selects whether meter will display measurement from Input 1 or Input 2
- 6 **I1-I2** displays the differential value of Input 1 minus Input 2
- 7 **MIN** displays minimum value since meter was last reset or turned on
- 8 **PRINT** sends displayed measurements to PC or printer
- 9 **HOLD** resets display to zero
- 10 **Two Inputs** (5 pin)
- 11 **External Power Supply** Socket
- 12 **Data Output** via RS232 interface to transmit measured values to PC

**Serviceman Technical Data**

**Meter**

- 2 Line Display Shows Both Inputs
- 4 Digit LCD Text Display
- Display of Pressure, Temperature, Flow and Rotational Speed
  - Pressure in PSI and Bar
  - Temperature in °F and °C
  - Flow in GPM and l/min.
  - Rotational Speed in RPM

**Housing**

- ABS Plastic Housing
- Protective Rubber Cover
- Carrying Strap
- Integral Stand

**Inputs**

- Two 5-pin push-pull Inputs
- 0-3 Volts (R=470 kΩ)
- 12 Bit A/D Converter
- Automatic Sensor Recognition
- 2 ms Scanning Rate

**Ambient Conditions**

- Operating Temperatures  
32°F to 122°F (0°C to 50°C)
- Storage Temperatures  
-4°F to 140°F (-20°C to 60°C)

**Output**

- RS232 Interface to transfer measured values to a PC. The SCSW-KIT-152 software and adapter kit is required for data transfer to a PC.

**Power Requirements**

- 9 Volt Rechargeable Ni-MH Battery
- Recharge circuit for use with external power supply.
- 5 Hour Battery Life



Test Meter Kits



**Kit Contents:**

- Case .....SCC-150
- Serviceman Meter .....SCM-152-2-02
- Transducers (Quantity 1 or 2) .....(See Below)
- Cable (Quantity 1 or 2) .....SCK-102-03-02
- Power Supply – Meter\* .....SCSN-450
- Instruction Manual\* .....SCM-152-TM

\* Included with Serviceman Meter

**Code for Ordering  
Serviceman Meter Kits:**

**PDS3 - X - XX - XX**      **Transducer Pressure Range**  
(Choose one or two)

**Diagnostic Style**

CODE	DESCRIPTION
2	PD Style
4	PDP Style
6	EMA3 Style (Female)

CODE	PRESSURE	COLOR
01	-14.5 – +145 PSI	Blue
06	0 – 870 PSI	Green
15	0 – 2175 PSI	Yellow
40	0 – 5800 PSI	Orange
60	0 – 8700 PSI	Red

**Additional Transducers**

**Code for Ordering Separately:**

**PD XXXXXX - XXXX**

**Pressure Range**

**Diagnostic Style**

CODE	DESCRIPTION
TA	PD Style
PTA	PDP Style
TEMA3	EMA3 Style (Female)

CODE	PRESSURE	COLOR
0100	-14.5 – +145 PSI	Blue
0600	0 – 870 PSI	Green
1500	0 – 2175 PSI	Yellow
4000	0 – 5800 PSI	Orange
6000	0 – 8700 PSI	Red

**PTA - 10000**

**Pressure Range**

**Diagnostic Style**

DIRECT PORT ONLY  
(1/2-14BSPP Thread)

PRESSURE	COLOR
0 – 14500 PSI	Red

**Flow Sensors**

**Code for Ordering Separately:**

**SCFT-XXXX - XXX**

**Diagnostic Style**

**Flow Range**

CODE	FLOW RATE
0004	0.2 – 4 GPM (1 – 15 l/min)
0116	1 – 16 GPM (4 – 60 l/min)
0380	3 – 80 GPM (10 – 300 l/min)
5160	5 – 160 GPM (20 – 600 l/min)

CODE	DESCRIPTION
PD	PD Style
PDP	PDP Style
EMA	EMA Style

**Hand-held Diagnostic Meter to Measure Pressure, Temperature, Flow and Rotational Speed for Hydraulic and Pneumatic Systems**

- Easy operation
- Rugged design
- Large display
- Auto sensor recognition
- MIN/MAX Memory
- On-line operation
- Multiple sensor inputs
- Battery monitoring



The Service Master meter is a state-of-the-art instrument available in either four or six channel models. The ergonomically designed case and large automatic scaling LCD display make it very easy to use in even the most demanding environments.

They are the perfect tool to capture diagnostic measurements at remote locations. Able to measure pressure, temperature, flow and rotational speed simultaneously, the data can be gathered and stored on a PC for later analysis.

The SCM-360 offers 125,000 data points and the SCM-450 offers 250,000 data points of storage. These measurements can easily be transferred to your PC via an RS232 interface and SensoWin™ 4.03 software which is compatible with Windows98 and newer operating systems.

As with all SensoControl equipment, the Service Master offers the latest in sensor recognition technology, eliminating the need for individual sensor setup. It also allows you to program the individual inputs to accept other data collection formats, such as 4-20 ma, or 0-10 Volt.

Parker Hannifin provides the most complete line of hydraulic and pneumatic diagnostic equipment available today. For more information contact the Quick Coupling Division or your local distributor.

F Diagnostic

SensoControl® Service Master  
Measure and Document Flow, Pressure, Voltage, Current,  
Temperature and Rotation Speed

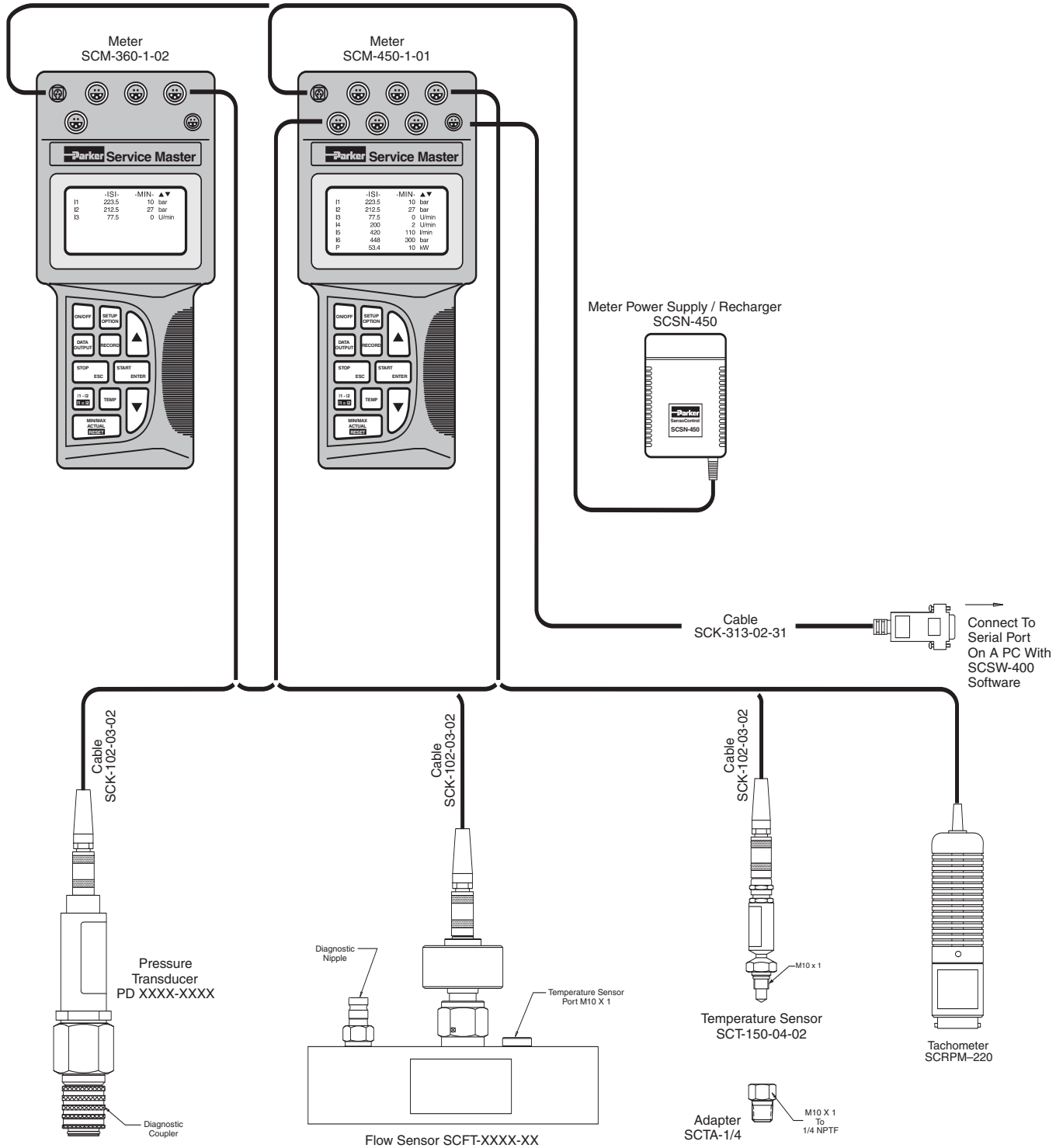

F Diagnostic

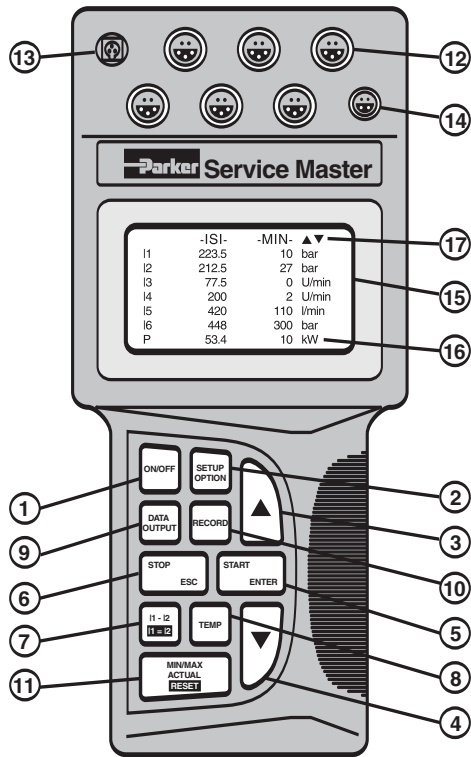

**Function Descriptions**

- 1 **ON/OFF** Turns meter on or off
- 2 **SETUP/OPTION** Change system settings
- 3/4 **ARROWS** Select line and function values
- 5 **START/ENTER** Change function values and start measurements
- 6 **STOP/ESC** Stop or terminate functions
- 7 **I1-I2** Differential value between input 1 and input 2.
- 8 **TEMP** Displays the measured temperature values for all channels
- 9 **DATA-OUTPUT** Displays output to PC, printer or graphic display
- 10 **RECORD** To record and store measurements
- 11 **MIN/MAX/ACTUAL** Displays the minimum, maximum and actual values. Reset deletes values
- 12 **INPUTS** Inputs for up to (6) sensors
- 13 **11-30 VDC** Input for external power supply and charging of internal battery
- 14 **DATA OUTPUT** RS232 port for connecting to the PC, printer, or external trigger module
- 15 **GRAPHIC LCD** Displays measured values, adjustment menus and graphics.
- 16 **ADDITIONAL LINE** Displays the power or flow runout values.
- 17 **STATUS LINE** Shows the designation of the measured value or the menu name.

**Technical Data**

**Meter**

- Digital LCD Text Display
  - 128x64 pixels
- Automatic Character Height Scaling
- Display of Pressure, Temperature, Flow and Rotational Speed
  - Pressure in PSI and Bar
  - Temperature in °F and °C
  - Flow in GPM and l/min.
  - Rotational Speed in RPM

**Inputs**

- Four or six, 5-pin push-pull style connectors
- Automatic Sensor Recognition
- 0-3 Volts (R=470 kΩ)
- 12 Bit A/D Converter
- 1 ms Scanning Rate (1-3 inputs)
- 2 ms Scanning Rate (4-6 inputs)

**Functions**

- Differential Value Measurement
- MIN/MAX Memory
- Online data transfer
- Battery level indicator
- Power calculation (display only)
- Flow run-out (display only)
- Auto power off

**Output**

- RS232 interface
- Adjustable baud rate up to 38400 BPS
- 8 data bits, 1 stop bit

**Power Requirements**

- Internal 7.2-volt rechargeable Ni-Cad battery
- Recharge circuit for use with external power supply.
- Operating time (Aprox. 5 hours)
- Excitation voltage (12-30 VDC)

**Memory Functions**

- Memory capacity
  - 125,000 data points (SCM-360)
  - 250,000 data points (SCM-450)
- Memory used in 25,000 data point intervals
- Variable storage rate
- Variable measuring period up to 100 hours
- Manual and automatic triggering

**Ambient Conditions**

- Operating Temperatures
  - 32°F to 122°F (0°C to 50°C)
- Storage Temperatures
  - 4°F to 140°F (-20°C to 60°C)
- Protection class IP54

**Housing**

- Glass reinforced polyamide
- 11-Key tactile touch membrane
- EMC Protection
  - Electromagnetic interference (DIN/EN 50081, Part 1)
  - Immunity to emitted interference (DIN/EN 50082, Part 2)

**Dimensions**

- Length/Height/Width
  - 9.25 x 4.19 x 2.09
  - (235 x 106 x 52 mm)

**Weight**

- 1.2 lbs (700 grams)

F Diagnostic

Test Meter Kits



Kit Contents:

- Case
- Service Master Meter
- Transducers (Quantity 2)
- Transducer Cable, 10' (Quantity 2)
- Power Supply – Meter\*
- SensoWin Software 4.03
- Computer Interface Cable
- Operating Manual\*

\* Included with Service Master Meter

**Service Master 360  
Meter Kit**

- SC-690
- SCM-360-1-01  
(See Below)
- SCK-102-03-02
- SCSN-450
- SCSW-400
- SCK-313-02-31

**Service Master 450  
Meter Kit**

- SC-690
- SCM-450-1-01  
(See Below)
- SCK-102-03-02
- SCSN-450
- SCSW-400
- SCK-313-02-31

**Code for Ordering  
Service Master Meter Kits:**

**PDSM XX - X - XX - XX**      **Transducer Pressure Range**  
(Choose two)

**Diagnostic Style**

CODE	DESCRIPTION
2	PD Style
4	PDP Style
6	EMA3 Style (Female)

**Meter Style**

CODE	PRESSURE	COLOR
01	-14.5 – +145 PSI	Blue
06	0 – 870 PSI	Green
15	0 – 2175 PSI	Yellow
40	0 – 5800 PSI	Orange
60	0 – 8700 PSI	Red

CODE	DESCRIPTION
36	Service Master 360 Meter
45	Service Master 450 Meter

Additional Transducers

**Code for Ordering Separately:**

**PD XXXXXX - XXXX**

**Pressure Range**

**Diagnostic Style**

CODE	DESCRIPTION
TA	PD Style
PTA	PDP Style
TEMA3	EMA3 Style (Female)

CODE	PRESSURE	COLOR
0100	-14.5 – +145 PSI	Blue
0600	0 – 870 PSI	Green
1500	0 – 2175 PSI	Yellow
4000	0 – 5800 PSI	Orange
6000	0 – 8700 PSI	Red

**PTA - 10000**

**Pressure Range**

**Diagnostic Style**

**DIRECT PORT ONLY**  
(1/2-14BSPP Thread)

PRESSURE	COLOR
0 – 14500 PSI	Red

Flow Sensors

**Code for Ordering Separately:**

**SCFT-XXXX - XXX**

**Diagnostic Style**

**Flow Range**

CODE	FLOW RATE
0004	0.2 – 4 GPM (1 – 15 l/min)
0116	1 – 16 GPM (4 – 60 l/min)
0380	3 – 80 GPM (10 – 300 l/min)
5160	5 – 160 GPM (20 – 600 l/min)

CODE	DESCRIPTION
PD	PD Style
PDP	PDP Style
EMA	EMA Style





### Pressure Transducer Options

- Six measurement ranges:  
Vacuum to 14,500 PSI
- Color coded for easy identification
- Corrosion resistant stainless steel housing
- Accuracy of .5% Full Scale (FS)
- Available with PD, PDP or EMA style diagnostic couplings



### Transducer Technical Data

	PD ** -0100	PD ** -0600	PD ** -1500	PD ** -4000	PD ** -6000	PTA-10000
Measuring Range (Pressure)	-14.5 to 235 PSI	0 to 870 PSI	0 to 2175 PSI	0 to 5800 PSI	0 to 8700 <sup>(1)</sup> PSI	0 to 14500 <sup>(2)</sup> PSI
Color Code	Blue	Green	Yellow	Orange	Red	Red
Measuring Range (Temp.)	-13°F to 221°F	-13°F to 221°F	-13°F to 221°F	-13°F to 221°F	-13°F to 221°F	-13°F to 221°F
Max. Overload Pressure	290 PSI	1450 PSI	3625 PSI	14500 PSI	14500 PSI	14500 PSI
Output Signal (Volts)	-0.2 to 2	0 to 3	0 to 3	0 to 3	0 to 3	0 to 3
Hysteresis (% FS Typical)	0.1	0.05	0.1	0.08	0.05	0.05
Repeatability (%FS Typical)	0.08	0.13	0.13	0.1	0.1	0.1
Non-conformity (%FS)	0.25	0.2	0.2	0.28	0.25	0.25
Response Time	1 ms	1 ms	1 ms	1 ms	1 ms	1 ms
Excitation Voltage	7-12 VDC	7-12 VDC	7-12 VDC	7-12 VDC	7-12 VDC	7-12 VDC

(1) Maximum Rated Pressure for PD Series Couplers is 6000 PSI.  
(2) Maximum Rated Pressure for EMA Series Couplers is 9000 PSI.

#### Materials of Construction

Transducer . . . . .Stainless steel  
Diaphragm . . . . .Stainless steel  
Coupler . . . . .Zinc Plated steel  
Seal . . . . .Fluorocarbon

#### Temperature Range

Working . . . . .-4° to 185°  
Fluid . . . . .-13° to 221°  
Storage . . . . .-40° to 257°

#### Output

Accuracy . . . . .0.5% FS  
Load . . . . .2m ohms  
Response time . . . . .<1 ms  
Output signal to noise . . . . .0.1%FS  
Resonant frequency . . . . .100 KHz

#### Voltage Requirement

7 to 12 VDC excitation voltage  
Permissible ripple . . . . .±2% ss  
Current requirement . . . . .5 mA

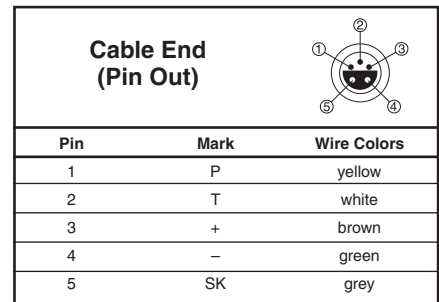

**Special Note:** All Parker SensoControl hand-held diagnostic meters are now equipped with the same 5-pin push-pull style connector ports. Accessories such as pressure sensors, temperature sensors, flow meters, tachometers and cables are all interchangeable between Serviceman and Service Master meters.



These flow sensors are a compact light-weight aluminum diagnostic tool capable of measuring pressure, temperature and flow from a single test point in a hydraulic system.

These flow sensors are designed to be used with a wide variety of hydraulic fluids. This design also minimizes the effect of viscosity changes. These units are manufactured from solid aluminum bar stock and are rated to 6000 PSI\* and temperatures of 0°F to +350°F. They are available in four sizes with flow measuring ranges from 0.2 – 160 GPM.

Flow sensors are provided with a choice of PD, PDP or EMA style diagnostic ports and are designed to be used with Serviceman™ and Service Master equipment.



**Flow Sensors Technical Data**

- Pressure Rating\* .....6000 PSI  
*\* SCFT-7160 is rated to 5000 PSI*
- Fluid Temperature Range .....0°F to +350°F
- Ambient Temperature Range .....0°F to +120°F
- Media/Compatibility .....Petroleum Based Fluids  
*(Contact factory for use with water based hydraulic fluids)*
- Flow Measurement Accuracy .....±1.0% Full Scale
- Voltage Input .....+7 to 12 VDC  
*(Supplied by SensoControl meter)*
- Current Requirement ......6mA
- Response Time ......50 ms
- Viscosity Range ......11 to 50 cSt

**Material Specifications**

- Flow Block ..... Anodized Aluminum
- Turbine ..... Stainless Steel
- Bearings .....Stainless Steel
- Seal Material .....Nitrile
- Electrical Connection ..... .5 Pin Push-Pull Style

**How to Order**

Measuring Range	Flow Sensor with PD Nipple	Flow Sensor with PDP Nipple	Flow Sensor with EMA Nipple	Inlet/Outlet Port Configuration	Length inches	Height inches	Width inches
0.2 – 4 GPM (1 – 15 l/min)	SCFT-0004-PD	SCFT-0004-PDP	SCFT-0004-EMA	3/4-16 ORB	5.35	4.61	1.46
1 – 16 GPM (4 – 60 l/min)	SCFT-0116-PD	SCFT-0116-PDP	SCFT-0116-EMA	1 1/16-12 ORB	7.48	5.12	2.44
3 – 80 GPM (10 – 300 l/min)	SCFT-0380-PD	SCFT-0380-PDP	SCFT-0380-EMA	1 5/16-12 ORB	7.48	5.28	2.44
5 – 160 GPM (20 – 600 l/min)	SCFT-5160-PD	SCFT-5160-PDP	SCFT-5160-EMA	1 5/8-12 ORB	8.35	5.91	2.44



Description	Serviceman	Service Master	Part Number
<b>Serviceman</b> Hand-held meter, 2 inputs (Includes SCSN-450 Power Supply)	•		SCM-152-2-02
<b>Service Master</b> Hand-held meter, 4 inputs, 125000 data points (Includes SCSN-450 Power Supply)		•	SCM-360-1-02
<b>Service Master</b> Hand-held meter, 6 inputs, 250000 data points (Includes SCSN-450 Power Supply)		•	SCM-450-1-01
<b>Storage Case</b>	•		SCC-150
<b>Storage Case</b>		•	SC-690
<b>Power Supply</b> 120 Volt AC	•	•	SCSN-450
<b>Connection Cable</b> Used between meter and sensors (3m length)	•	•	SCK-102-03-02
<b>Extension Cable</b> Used in series with connection cables (5m length)	•	•	SCK-102-05-12
<b>Temperature Sensor</b> Used with Parker Flow Sensors or SCTA-1/4 Port Adapter (Requires standard connection cable)	•	•	SCT-150-04-02
<b>Port Adapter</b> Converts M10X1 to 1/4" male NPT thread	•	•	SCTA-1/4
<b>Tachometer</b> To measure rotational speed (0 to 10,000 RPM)	•	•	SCRPM-220
<b>Contact Adapter</b> For SCRPM-220 Tachometer	•	•	SCRPMA-001
<b>Focus Adapter</b> For SCRPM-220 Tachometer	•	•	SCRPMA-002
<b>Diagnostic Test Hose Assembly</b> Used with PD style Parker Transducers and diagnostic nipples	•	•	PDH-19
<b>Voltage Adapter</b> Used with auxiliary sensors	•	•	SCMA-VADC-250
<b>Data Cable and Software</b> To connect the Serviceman meter to a PC	•		SCSW-KIT-152
<b>SensoWin 4.03 Software</b> For data transfer from the Service Master meter to a PC		•	SCSW-400
<b>Data Cable</b> Used between the Service Master meter and a PC		•	SCK-313-02-31

F Diagnostic

**Special Note**

All Parker SensoControl hand-held diagnostic meters are now equipped with the same 5-pin push-pull style connector ports. This means accessories such as pressure sensors, temperature sensors, flow meters, tachometers and cables are all interchangeable between Serviceman and the Service Master meters.



**Temperature Sensor**

for Serviceman and Service Master. Can be used with Parker flow sensors or with an SCTA-1/4 port adapter. Accuracy: ±1.5% Full scale Temperature range: -13°F to 257°F (-25°C to 125°C)

**Part Number**  
SCT-150-04-02



**SCRPM Tachometer**

for Serviceman and Service Master Meters. Displays a precision measurement of rotational speed. 5-pin push-pull style connector.

**Part Number**  
SCRPM-220

**Technical Data**

Measuring Range . . . . .20 – 10,000 RPM  
Measuring Distance . . . . .0.1 – 19.5 in  
Accuracy . . . . .0.5%  
Excitation Voltage . . . . .7 – 9 VDC  
Output Signal . . . . .0 – 3 VDC  
Resolution . . . . .0.5 RPM

**Tachometer Adapters**

Contact Adapter for belt drive/wheel.

**Part Number**  
SCRPMA-001

Focus Adapter for confined areas.

**Part Number**  
SCRPMA-001



**Voltage Adapter**

for use with Auxiliary Sensors to Serviceman and Service Master. Input: 0 - 20 MA or 0 - 10 VDC Accuracy: 0.25% FS

**Part Number**  
SCMA-VADC-250



**5 pin to 5 pin Cables**

Flow sensor, transducer and temperature probe cables for both Serviceman and Service Master.

<b>Length</b>	<b>Part Number</b>
10 ft (3 m)	SCK-102-03-02
<b>Extension Cable</b>	
16.4 ft (5 m)	SCK-102-05-12

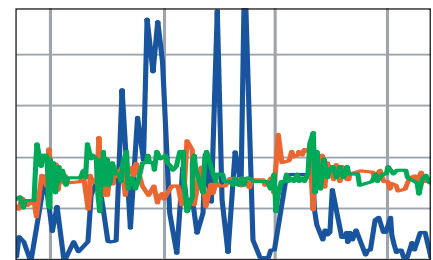

**SensoWIN™ 4.03 Software**

for data transfer from the Service Master Meter to a PC (Windows 98 and newer).

**Part Number**  
SCSW-400



**Data Cable/Software**

for use between the Serviceman Meter and a PC (Windows 98 and newer).

**Part Number**  
SCSW-KIT-152



**Features**

- Flush-face poppet valves minimize air inclusion and spillage, provide easy-to-clean surfaces, and help to prevent contamination.
- Grip-tight knurled sleeves help to make connecting and disconnecting easy, even while wearing gloves.
- Nipples are machined from high tensile steel for strength to withstand 6000 PSI continuous operating pressure. BPD nipples offer features similar to the standard steel PD nipples with the added feature of a brass body.
- PD nipples are designed to meet or exceed SAE J1502 and ISO 15171-1 design and performance specifications.
- End connections include pipe, O-ring, metric thread, bulkhead, 37° Flare, ORFS and bite-type.

**Applications**

PD Series couplings provide easy connection for mechanical gauges or specialized diagnostic equipment like SensoControl®.

Typically, PD or BPD nipples are permanently mounted in the system at threaded test ports, in rigid tubing or in hose assemblies. PD couplers are attached to test instruments.

Couplers align to the mating nipples without threading. This allows gauges, transducers and other test equipment to be snapped into place without difficulty.

**Note:** Protective dust plugs and caps play a crucial role in the life of a quick coupling and no purchase of a hydraulic quick coupling is complete without the selection of an appropriate dust plug and cap. See pages noted in Table of Contents for dust plugs and caps for the Parker full line of hydraulic couplings.

**Ordering information**

Coupler/Nipple Material
<ul style="list-style-type: none"> <li>• Prefix "B" for Brass body</li> <li>• Prefix "SS" for Stainless Steel body</li> <li>• Standard body material is Steel</li> </ul>

Optional Seals Suffix*				
No suffix is required when ordering products with the standard Nitrile seals. When specifying an optional seal, refer to the following chart to determine the appropriate suffix.**				
Coupling Series	Ethylene Propylene	Fluoro-carbon	Neoprene	Perfluoro-elastomer
PD Series	W	Y	Z	
PDP Series	W	Y	Z	

\*To select proper seal materials, see Fluid Compatibility Chart in Appendices section, or contact your Parker Quick Coupling Distributor.

\*\*N/A = Not Available; STD = Standard (No Suffix Needed)

**Specifications**

Body Size	1/8			
	PD Coupler	PD Nipple	BPD Nipple	Assembly
Description	PD242	PD361	BPD343Y	—
Part Number	PD242	PD361	BPD343Y	—
Body Material (Steel)	Carbon Steel	High Tensile Steel	Brass	—
Rated Pressure (PSI)	6000	6000	300	6000
Temperature Range (STD Seals) Nitrile	-40°F to +250°F		-15°F to +400°F (Fluorocarbon)	-40°F to +250°F
Rated Flow (GPM)	—	—	—	0.8
Max. Recommended Flow (GPM)	—	—	—	4.0
Burst Pressure (PSI/Min)	23,000	40,000	—	17,000
Vacuum Data (Inches Hg)	27.5	27.5	27.5	27.5
Pressure Drop at Rated Flow (PSI) with 200 SUS Fluid	—	—	—	56
Spillage at 15 PSI (ml)-Assembly	0.1 per disconnect			
Air Inclusion (ml)-Assembly	0.02 per connect			
Connect Force-Assembly	41 Lbs. (100 PSI)			
Disconnect Force-Assembly	20 Lbs. (100 PSI)			

**PD Series DUST CAP**



Body Size (in.)	Dust Cap Part No.
1/8	PD6-285

Couplers

Female Thread

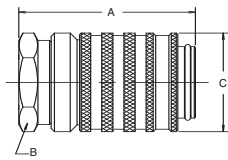

Body Size (in.)	Part No.	Female Thread NPTF	Female Thread ORB	Dimensions (in.)			Wt. (LB.) P/Piece
				Overall Length	Wrench Flats	Largest Diameter	
				A	B	C	
1/8	PD222	1/8-27	—	1.67	0.81	0.96	0.20
1/8	PD240	—	7/16-20	2.12	0.81	0.96	0.26
1/8	PD242	1/4-18	—	2.12	0.81	0.96	0.25
1/8	SSPD242Y**	1/4-18	—	2.12	0.81	0.96	0.25
1/8	PD260	—	9/16-18	2.12	0.81	0.96	0.24

Male Thread

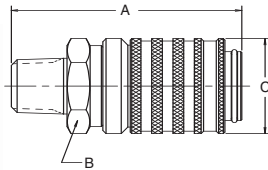

Body Size (in.)	Part No.	Male Thread NPTF	Male Thread ORB	Dimensions (in.)			Wt. (LB.) P/Piece
				Overall Length	Flats	Largest Diameter	
				A	B	C	
1/8	PD243	1/4-18	—	2.26	0.81	0.96	0.23

Nipples

Female Pipe Thread

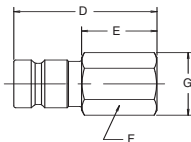

Body Size (in.)	Part No.	Thread Size NPTF	Overall Length	Exposed Length	Dimensions (in.)			Wt. (LB.) P/Piece
					Hex Size	Largest Diameter		
				D	E	F	G	
1/8	PD322	1/8-27	1.48	0.78	0.56	0.65	0.06	
1/8	PD342	1/4-18	1.63	0.93	0.75	0.87	0.12	

Male Pipe Thread

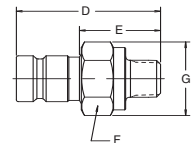

Body Size (in.)	Part No.	Thread Size NPTF	Overall Length	Exposed Length	Dimensions (in.)			Wt. (LB.) P/Piece
					Hex Size	Largest Diameter		
				D	E	F	G	
1/8	PD323	1/8-27	1.55	0.85	0.69	0.79	0.17	
1/8	BPD323Y*	1/8-27	1.44	0.74	0.63	0.72	0.17	
1/8	BPD343Y*	1/4-18	1.48	0.78	0.69	0.79	0.06	
1/8	PD343	1/4-18	1.48	0.78	0.69	0.79	0.06	
1/8	SSPD343Y**	1/4-18	1.48	0.78	0.69	0.79	0.06	
1/8	PD363	3/8-18	1.50	1.13	0.81	0.96	0.09	

Metric Thread

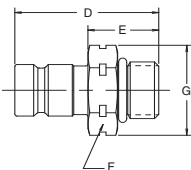

Body Size (in.s)	Part No.	Thread Size Metric	Overall Length	Exposed Length	Dimensions (in.)			Wt. (LB.) P/Piece
					Hex Size	Largest Diameter		
				D	E	F	G	
1/8	PD357	M10 x 1.0	1.80	1.10	0.69	0.79	0.17	
1/8	PD367C	M14 x 1.5	1.50	0.80	0.75	0.87	0.08	
1/8	PD3107	M16 x 1.5	1.54	0.84	0.88	1.01	0.08	
1/8	PD3127	M18 x 1.5	1.60	0.90	0.94	1.08	0.09	
1/8	PD3147	M20 x 1.5	1.50	0.80	0.75	0.87	0.07	

Male Straight Thread

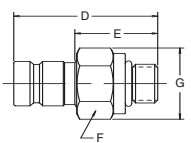

Body Size (in.)	Part* No.	Thread Size ORB	Overall Length	Exposed Length	Dimensions (in.)			Wt. (LB.) P/Piece
					Hex Size	Largest Diameter		
				D	E	F	G	
1/8	PD331	3/8-24	1.80	1.10	0.69	0.79	0.17	
1/8	PD341	7/16-20	1.60	0.90	0.69	0.79	0.08	
1/8	PD351	1/2-20	1.32	0.62	0.63	0.72	0.05	
1/8	PD361	9/16-18	1.32	0.62	0.69	0.79	0.06	

\* Note: Add -6 to part number to include dust cap, for example PD343-6

\* BPD designates brass body, Fluorocarbon seal standard

\*\* SSPD designates 316SS body, Fluorocarbon seal standard



Nipples

Bulkhead Triple-Lok

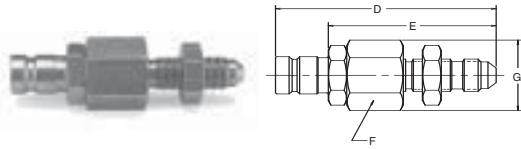

Body Size (in.)	Part No. Steel	Thread Size	Tube Size	Dimensions (in.)				Wt. (LB.) P/Piece	
				Overall Length	Exposed Length	Hex Size	Largest Diameter		
				D	E	F	G		
1/8	PD345	7/16-20	1/4	2.92	2.22	0.81	0.94	0.19	
1/8	PD355	1/2-20	5/16	2.92	2.22	0.81	0.94	0.19	
1/8	PD365	9/16-18	3/8	3.00	2.30	0.81	0.94	0.20	

Bulkhead Seal-Lok

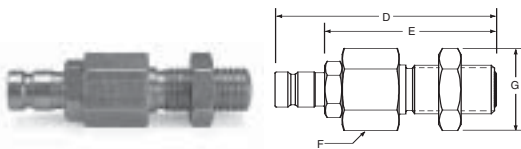

Body Size (in.)	Part No. Steel	Thread Size	Tube Size	Dimensions (in.)				Wt. (LB.) P/Piece	
				Overall Length	Exposed Length	Hex Size	Largest Diameter		
				D	E	F	G		
1/8	PD346	9/16-18	1/4	2.98	2.27	0.81	0.94	-	
1/8	PD366	11/16-16	3/8	3.08	2.37	1.00	1.16	-	
1/8	PD386	13/16-16	1/2	3.18	2.47	1.12	1.30	-	

Tube End Nipples\*

Triple-Lok  
PD — — BTX

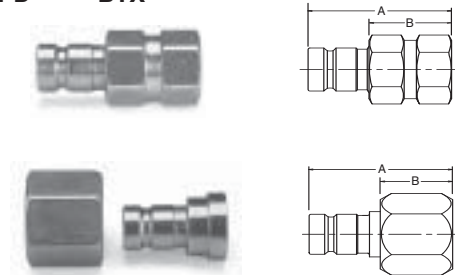

Body Size (in.)	Part No. Steel	Tube Size	Dimensions (in.)		Wt. (LB.) P/Piece	
			Overall Length	Exposed Length		
			A	B		
1/8	PD34BTX	1/4	1.64	0.94	0.10	
1/8	PD36BTX	3/8	1.66	0.96	0.09	
			A	B		
1/8	PD38BTX	1/2	1.17	0.47	0.12	
1/8	PD312BTX	3/4	1.39	0.69	0.27	

\* Tube end nipples are designed to meet the performance standards of the tube or hose fitting connection, which may or may not meet SAE J1502 Standards.

Ferulok  
PD — — BTU



Body Size (in.)	Part No. Steel	Tube Size	Dimensions (in.)		Wt. (LB.) P/Piece	
			Overall Length	Exposed Length		
			A	B		
1/8	PD38BTU	1/2	1.40	0.70	-	

\* Tube end nipples are designed to meet the performance standards of the tube or hose fitting connection, which may or may not meet SAE J1502 Standards.

Seal-Lok  
PD — — BTL

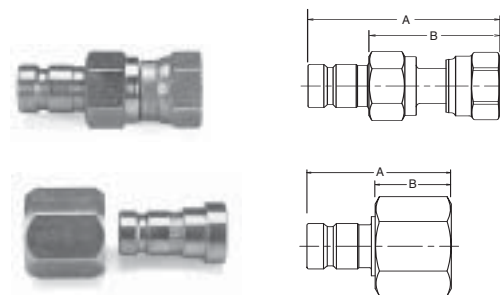

Body Size (in.)	Part No. Steel	Tube Size	Dimensions (in.)		Wt. (LB.) P/Piece	
			Overall Length	Exposed Length		
			A	B		
1/8	PD34BTL	1/4	2.18	1.48	0.12	
1/8	PD36BTL	3/8	2.30	1.60	0.14	
			A	B		
1/8	PD38BTL	1/2	1.57	0.83	0.13	
1/8	PD310BTL	5/8	1.16	0.46	0.19	

\* Tube end nipples are designed to meet the performance standards of the tube or hose fitting connection, which may or may not meet SAE J1502 Standards.

Note: Add -6 to part number to include dust cap, for example PD343-6





**Features**

- Made to connect under pressure up to 6000 psi
- Grip-tight knurled sleeves help to make connecting and disconnecting easy, even while wearing gloves.
- Nipples are machined from high tensile steel for strength to withstand 6000 PSI continuous operating pressure.
- End connections include pipe, O-ring, 37° Flare and ORFS
- Durable Ball Valve Nipple.
- Coupler is unvalved to allow gauges and transducers to return to zero when disconnected.

**Specifications**

Body Size		1/8"	
Description	PDP Coupler	PDP Nipple	Assembly
Body Material (Steel)	Carbon Steel	High Tensile Steel	—
Rated Pressure (PSI)	—	6000	6000
Temperature Range (STD Seals) Nitrile	-40°F to +250°F		
Connect Force-Assembly	6 Lbs (0 PSI - 6000 PSI)		
Disconnect Force-Assembly	7 Lbs (0 PSI - 6000 PSI)		

**Coupler (connect-under-pressure)**

**Female Thread**

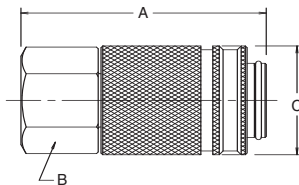
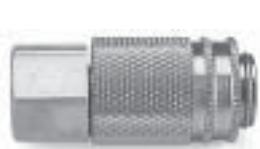

**Applications**

The PDP Series couplings provide easy connection for mechanical gauges or specialized diagnostic equipment like SensoControl.

Typically, PDP nipples are permanently mounted in the system at threaded test ports, in rigid tubing or in hose assemblies. PDP couplers are attached to test instruments.

Locking balls align the couplers to the mating nipples without threading, so gauges, transducers and other test equipment can be snapped into place without difficulty.

Parker's PDP Series couplings offer the advantages of PD couplings, but are designed to connect easily and quickly under full system pressure up to 6000 PSI (operating).

PDP couplers and nipples push to connect with a constant force of only six pounds. Then the coupler base is turned to open the valve and complete the connection. In the connected position, the coupler base blocks the retracting sleeve to prevent accidental disconnects.

**Ordering information**

Coupler/Nipple Material
Standard body material is steel.

Optional Seals Suffix*				
No suffix is required when ordering products with the standard Nitrile seals. When specifying an optional seal, refer to the following chart to determine the appropriate suffix.**				
Coupling Series	Ethylene Propylene	Fluoro-carbon	Neoprene	Perfluoro-elastomer
PD Series	W	Y	Z	
PDP Series	W	Y	Z	

\*To select proper seal materials, see Fluid Compatibility Chart in Appendices section, or contact your Parker Quick Coupling Distributor.

\*\*N/A = Not Available; STD = Standard (No Suffix Needed)

Body Size (in.)	Part No. Steel	Thread Size NPTF	Dimensions (in.)			Wt. (LB.) P/Piece
			Overall Length	Wrench Flats	Largest Diameter	
			A	B	C	
1/8	PDP242	1/4-18	2.15	0.81	0.96	—

**PDP Series DUST CAP**



Body Size (in.)	Dust Cap Part No.
1/8	PD6-285

Nipples\*  
(connect-under-pressure)

Male Pipe

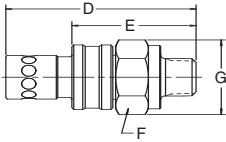

Body Size (in.)	Part No. Steel	Thread Size NPTF	Overall Length	Dimensions (in.)			Largest Diameter	Wt. (LB.) P/Piece
				Exposed Length	Hex Size	G		
1/8	PDP323	1/8-27	2.02	1.46	0.69	0.79	0.26	
1/8	PDP343	1/4-18	1.48	0.93	0.69	0.79	0.12	

Straight Thread

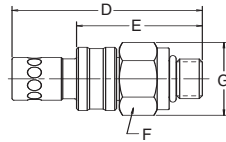

Body Size (in.)	Part No. Steel	Thread Size ORB	Overall Length	Dimensions (in.)			Largest Diameter	Wt. (LB.) P/Piece
				Exposed Length	Hex Size	G		
1/8	PDP341	7/16-20	2.06	1.50	0.69	0.79	0.12	
1/8	PDP361	9/16-18	1.48	0.93	0.69	0.79	0.07	

\*Add -6 to part number to include dust cap.

Triple-Lok

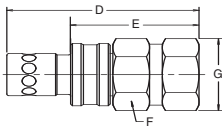

Body Size (in.)	Part No. Steel	Tube Size	Overall Length	Dimensions (in.)			Largest Diameter	Wt. (LB.) P/Piece
				Exposed Length	Hex Size	G		
1/8	PDP34BTX	1/4	2.11	1.55	0.69	.80	-	
1/8	PDP36BTX	3/8	2.13	1.57	0.69	.80	-	

Seal-Lok

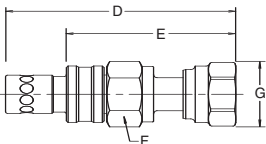

Body Size (in.)	Part No. Steel	Tube Size	Overall Length	Dimensions (in.)			Largest Diameter	Wt. (LB.) P/Piece
				Exposed Length	Hex Size	G		
1/8	PDP34BTL	1/4	2.65	2.09	.69	.80	-	
1/8	PDP36BTL	3/8	2.77	2.21	.81	.94	-	



**Features**

- Knurled sleeve allows simple twist-to-connect operation without the use of tools
- Rugged design allows connect-under-pressure operation up to 5800 psi
- Maximum rated working pressure of 9000 psi exceeds the requirements of most applications
- Integral threaded dust cap protects the test point from damage and contamination
- EMA fittings are machined from solid barstock and protected with zinc plating and a chromium 6 free finish.
- Stainless steel springs for corrosion resistance
- Elastomeric interface and valve seals provide leak free operation
- Compact design and optional high pressure hose assemblies provide flexibility for tight space requirements

**Applications**

EMA couplings provide easy diagnostic connections for Parker SensoControl® equipment or mechanical gages. EMA test points are typically permanently plumbed into a fluid system at locations where pressure measurements are required for maintenance or testing. Integral pressure cap protects the test point from damage and prevents contamination of the fluid system. Proven twist-to-connect design allows the test points to be connected even when the system is in operation and the test points are pressurized. EMA's compact design and optional high pressure hose assemblies allow extra flexibility for the location of system test points.

Although designed primarily for diagnostic applications, EMA fittings and hose assemblies are ideal for a wide range of applications that require compact high pressure connections and limited flow rates.

**Specifications**

<b>Body Size</b>	<b>1/8</b>
<b>Rated Pressure (PSI)</b>	9000 PSI
<b>Max Connect-Under-Pressure (PSI)</b>	5800
<b>Rated Flow (GPM)</b>	0.8
<b>Body Material</b>	Zinc Plated Steel
<b>Seal Material (std.)</b>	Nitrile/Fluorocarbon
<b>Temperature Range (std. seals)</b>	-15° to +250° F

**Male Pipe Thread**

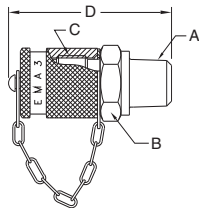

Part No.	Port Thread Size	Hex Size (mm)	Interface Thread Size	Overall Length	Wt. (LB.) P/Piece
	A	B	C	D	
EMA3/1/8NPT	1/8-27NPT	17	M16X2.0	1.81	0.15
EMA3/1/4NPT	1/4-18NPT	17	M16X2.0	1.98	0.16
EMA3/1/4NPT71	1/4-18NPT	17	M16X2.0	1.95	0.16

Stainless Steel

**SAE Straight Thread**

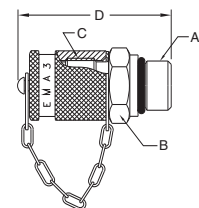

Part No.	Port Thread Size	Hex Size (mm)	Interface Thread size	Overall Length	Wt. (LB.) P/Piece
	A	B	C	D	
EMA3/7/16-20UNF-2A*	7/16-20UNF-2A	17	M16X2.0	1.88	0.15
EMA3/9/16-18UNF-2A*	9/16-18UNF-2A	19	M16X2.0	1.88	0.17

\* O-Ring seal on port

**Metric Straight Thread**

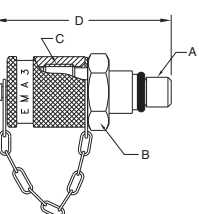

Part No.	Port Thread Size	Hex Size (mm)	Interface Thread Size	Overall Length	Wt. (LB.) P/Piece
	A	B	C	D	
EMA3/M8X1OR*	M8X1	17	M16X2.0	1.81	0.15
EMA3/10X1ED**	M10X1	17	M16X2.0	1.85	0.15
EMA3/12X1.5ED**	M12X1.5	17	M16X2.0	1.94	0.16
EMA3/14X1.5ED**	M14X1.5	19	M16X2.0	1.94	0.16

\* O-Ring seal on port

\*\* Molded seal on port

**British Parallel Pipe**

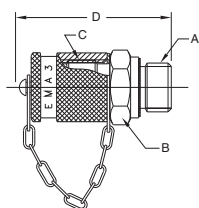

Part No.	Port Thread Size	Hex Size (mm)	Interface Thread Size	Overall Length	Wt. (LB.) P/Piece
	A	B	C	D	
EMA3/1/8ED**	1/8 BSPP	19	M16X2.0	1.77	0.15
EMA3/1/4ED**	1/4 BSPP	19	M16X2.0	1.94	0.16
EMA3/3/8ED**	3/8 BSPP	21	M16X2.0	1.94	0.16

\*\* Molded seal on port



EMA Gauge Adapter

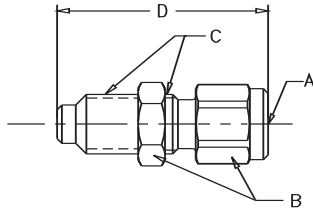

Part No.	Port Thread Size	Hex Size (mm)	Port Thread Size	Overall Length	Wt. (LB.) P/Piece
	A	B	C	D	
MAV1/4NPT-MA3	1/4-18NPT	19	M16X2.0	2.22	0.16
MAV1/4NPT-MA3-KM Includes Dust Cap	1/4-18NPT	19	M16X2.0	2.22	0.23

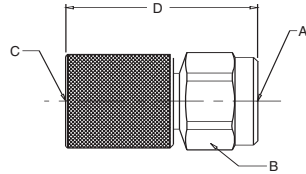

Part No.	Port Thread Size	Hex Size (mm)	Port Thread Size	Overall Length	Wt. (LB.) P/Piece
	A	B	C	D	
MAVMD1/4NPT-MA3	1/4-18NPT	19	M16X2.0	2.22	0.18

Union

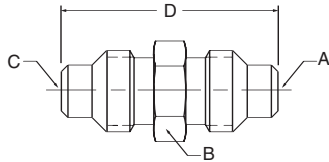

Part No.	Port Thread Size	Hex Size (mm)	Port Thread Size	Overall Length	Wt. (LB.) P/Piece
	A	B	C	D	
EMA3VS	M16X2.0	17	M16X2.0	1.65	0.11

Transducer Adapters 1/2-14BSPP Thread\*

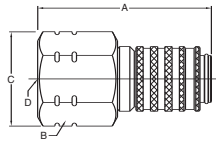

Part No.	Overall Length	Hex Size	Largest Diameter	Port Thread Size	Interface Thread Size	Wt. (LB.) P/Piece
	A	B	C	D	E	
PD288	2.52	1.19	1.38	1/2-14BSPP	-	0.35

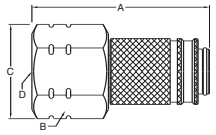

Part No.	Overall Length	Hex Size	Largest Diameter	Port Thread Size	Interface Thread Size	Wt. (LB.) P/Piece
	A	B	C	D	E	
PDP288	2.58	1.19	1.38	1/2-14BSPP	-	0.35

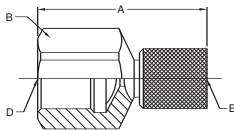

Part No.	Overall Length	Hex Size Metric	Largest Diameter	Port Thread Size	Interface Thread Size	Wt. (LB.) P/Piece
	A	B	-	D	E	
SCA-1/2-EMA-3	2.07	27mm	-	1/2-14BSPP	M16X2.0	0.30

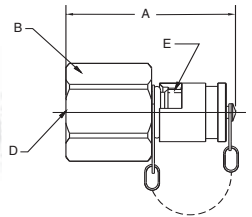

Part No.	Overall Length	Hex Size Metric	Largest Diameter	Port Thread Size	Interface Thread Size	Wt. (LB.) P/Piece
	A	B	-	D	E	
SCA-1/2-EMA-3-S	2.07	27mm	-	1/2-14BSPP	M16X2.0	0.30

\* Note: For old style M22X1.5 thread contact the division

Flexible Hose

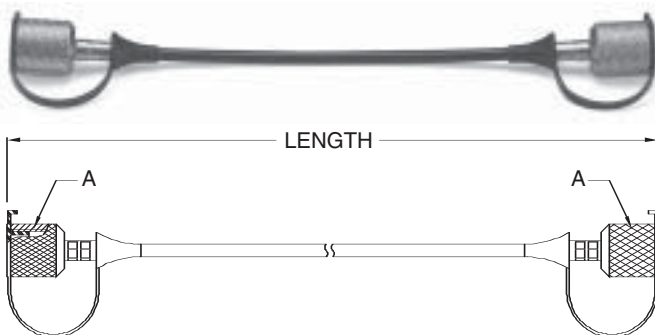

Part No.	Length (in.)	Length (mm)	Thread Size A
SMA3-200	7.90	200	M16x2.0
SMA3-400	15.75	400	M16x2.0
SMA3-800	31.50	800	M16x2.0
SMA3-2000	78.75	2000	M16x2.0
SMA3-4000	157.50	4000	M16x2.0

Note: Other lengths available upon request.  
Maximum pressure rating for test hose is 9000 psi.



**Features**

These diagnostic fluid sampling products are designed to provide an easy access point for obtaining fluid samples. A permanently mounted test point eliminates the need to shut down or break lines when taking samples and reduces the chances of contamination. Fluid analysis is crucial in both engines and hydraulic systems as it can reveal problems with filtration and other internal components. Early detection can prevent costly repairs, unscheduled maintenance and production downtime. These fluid sampling nipples should be installed in either low pressure or return lines. For the most accurate monitoring, fluid samples should be constantly taken from the same location.

**Specifications**

Body Size (in.)	1/8
Rated Pressure (psi)	500
Temperature Range (std seals: Fluorocarbon)	-40° to +250°F
Seal material	Fluorocarbon



**Couplers**

**Female Thread**

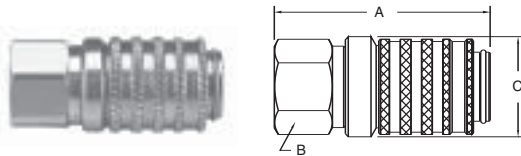

Body Size (in.)	Part No.	Female Thread NPTF	Female Thread ORB	Dimensions (in.)			Largest Wt. (LB.) P/Piece
				Overall Length	Wrench Flats	Hex Diameter	
				A	B	C	
1/8	PDFS242	1/4-18	-	2.15	0.81	0.96	0.25

**Nipples**

**Male Straight Thread**

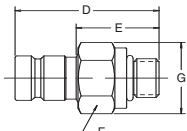

**Male Pipe Thread**

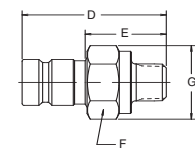

**Metric Thread**

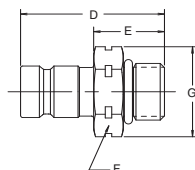

Body Size (in.)	Part No.	Thread Size ORB or NPTF	Thread Size METRIC	Dimensions (in.)				Largest Wt. (LB.) P/Piece
				Overall Length	Exposed Length	Hex Size	Hex Diameter	
				D	E	F	G	
1/8	BPDFS341	7/16-20 ORB		1.60	0.90	0.69	0.79	0.08
1/8	BPDFS343	1/4-18 NPTF		1.48	0.78	0.69	0.79	0.06
1/8	BPDFS357		M10 x 1.0	1.80	1.10	0.69	0.79	0.17
1/8	PDFS-PROBE*		NA	-	-	-	-	-
1/8	PROBE HOLDER							

Fluorocarbon seal is standard.

**Dust Cap PD6-285 is recommended.**

\* Reuseable PROBE HOLDER must be used with PDFS-PROBE

**Sampling Kits**

**Note:** When you purchase either of the sampling kits, you receive the PAR-Test™-complete laboratory analysis included in the initial cost. This includes particle count, viscosity, water content and spectra chemical analysis of over 20 wear metals and additives.

Body Size (in.)	Part No.	Description
1/8	PDFS-TEST	Sampling Kit
1/8	PDFS-TEST-P*	Sampling Kit W/Probe



## Ordering Information

### Diagnostic Products

When ordering Parker coupler bodies and nipples, please state the part number of each type of coupler body and each type of nipple desired. List coupler bodies and nipples as separate items rather than in combinations. Be sure to double check thread or hose sizes of items required.

Many of Parker's coupling products are available with unique non-standard options well suited to very specific applications. Examples of unusual end use applications might include: high temperatures (above 250° F), extremely caustic/corrosive solutions passing through the coupling, external/environmental corrosion situations, or other high wear and tear situations such as dragging the product along the ground. Please see the Fluid Compatibility Chart at the end of the catalog for a guide in selecting material for various media. It is always recommended that the Quick Coupling Division be contacted with any questions concerning specific product application needs.

Typically, a prefix or suffix is added to the base part number to specify a non-standard O-ring seal, or special option. The Optional Seals Suffix chart illustrates the designations.

Please Note: Certain couplings series have additional "Special Order Information" which should be referred to in ordering those products. If applicable to the product, "Special Order Information" is found next to the Features and Specifications charts.

Coupler/Nipple Material
<ul style="list-style-type: none"> <li>• Prefix "B" for Brass body</li> <li>• Prefix "SS" for Stainless Steel body</li> <li>• Standard body material is Steel</li> </ul>

Optional Seals Suffix*				
No suffix is required when ordering products with the standard Nitrile seals. When specifying an optional seal, refer to the following chart to determine the appropriate suffix.**				
Coupling Series	Ethylene Propylene	Fluoro-carbon	Neoprene	Perfluoro-elastomer
PD Series	W	Y	Z	
PDP Series	W	Y	Z	

\*To select proper seal materials, see Fluid Compatibility Chart in Appendices section, or contact your Parker Quick Coupling Distributor.

\*\*N/A = Not Available; STD = Standard (No Suffix Needed)

### Diagnostic Products

### Test Port Coupling-Selection Guide

	Valving	Body Size	Material* Br SS S P	Locking Mechanism	Std. Seal Material	Temp Range**	Rated Pressure
<b>Test Port</b>							
PD Series	Flush Face	1/8"	● ● ●	Ball	Nitrile	-40° to +250° F	6000 PSI
PDP Series	Ball	1/8"	●	Ball	Nitrile	-40° to +250° F	6000 PSI
EMA3 Series	Poppet	1/8"	● ●	Threads	Nitrile/Fluorocarbon	-15° to +250° F	9000 PSI

\* See Fluid Compatibility chart and/or consult factory for questions regarding proper material for specific applications.

CODE: Br = Brass; SS = Stainless Steel; S = Steel; P = Plastic

\*\*Temperature Range for standard seal material.

**Note:** See the Specifications Table for PD and PDP Series for more information.

SensoControl® diagnostic product's technical information subject to change.

