



H&L's 1 3/4SP Teeth are produced from aircraft quality Chrom-Moly grade alloy steels to enhance tooth **DURABILITY** and long **LASTING SHARPNESS!**



Malleable tooth pocket clip provides ease of crimping installation!

Submerged-arc welding clip-to-blade process creates maximum weld penetration!

444-514BHN
HARDNESS!

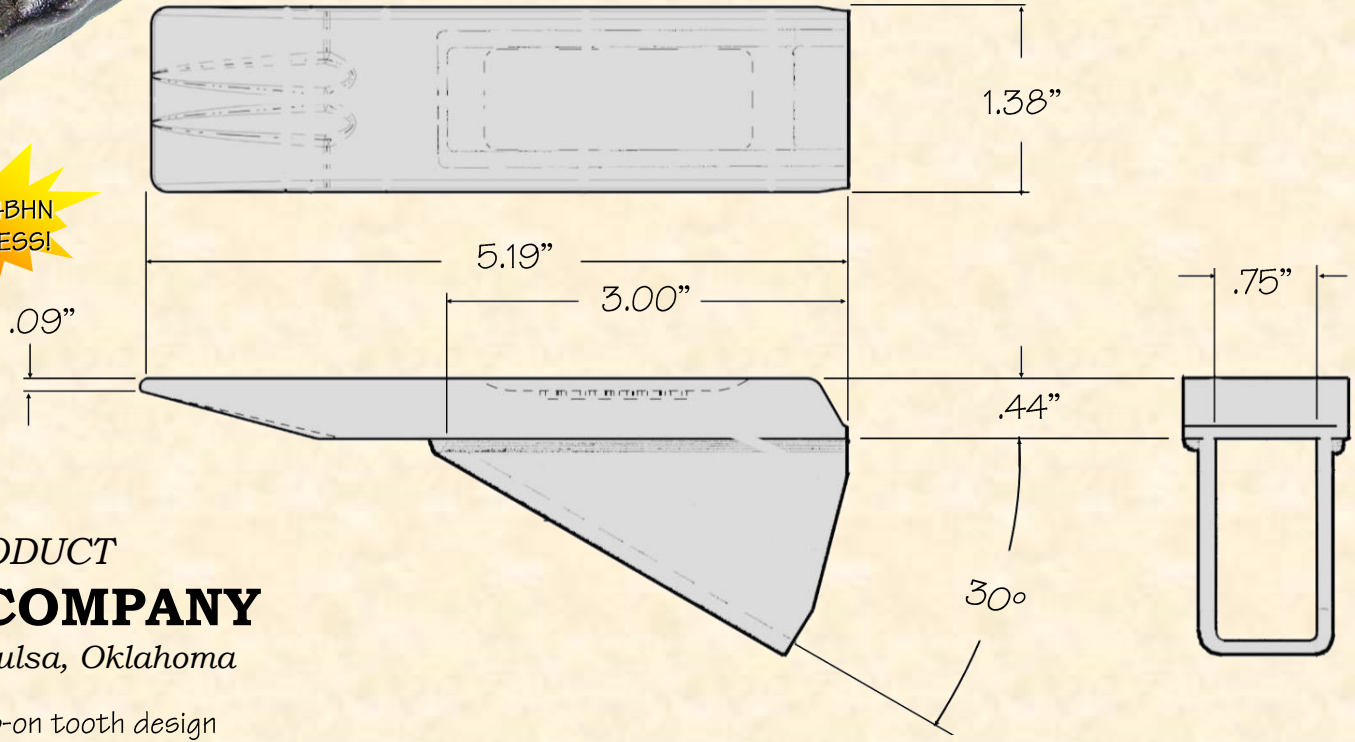

ORIGINAL PRODUCT
H&L® TOOTH COMPANY
Factory Direct Made in Tulsa, Oklahoma

The "OEM" fabrication Crimp-on tooth design

1 3/4SP

Sharp Penetration
1.0#/10.45kgs.

*H&L Tooth Company History since 1931:
This small fabricated ripping tooth was first designed and introduced in 1941.
H&L's Crimp-on Tooth system was first developed to fit a Model 16, Adam's
Road Maintainer. Today, copies of the 1 3/4SP tooth are being produced by
many companies worldwide, if it doesn't say H&L its not the ORIGINAL!*