

# Lifting Beams

## Model 21 - Twin Hoist Rotating Lifting Beams

A specially designed lifting and rotating beam using two cranes or two hoists to horizontally rotate a load. A position locking pin holds the load rotation at a designated position. Available with motorized rotation.



### PRODUCT FEATURES:

- Wide range of sizes and capacities available.
- Complies with ASME standards.

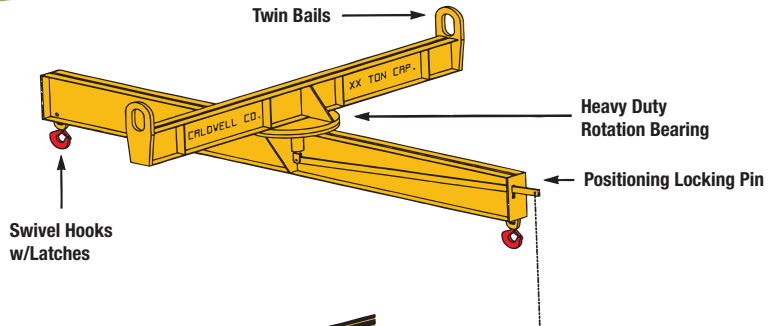

### OPTION A

#### TWIN HOOKS

Used in conjunction with basket hitch slings.



### OPTION B

#### J HOOKS

Generally required to lift paper rolls or similar application. (Use Paper Roll Lifters - Application Evaluation, page A.36.)

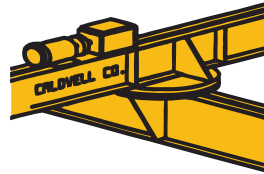

### OPTION C

#### MOTORIZED ROTATION

Allows remote positioning of a load.



### OPTION D

#### LOWER HEADROOM BAILS

Utilized when headroom must be held to a minimum. Crane hook data must be supplied, see page A.22.

## Model 28 - Chlorine Cylinder Lifting Beam

Designed to efficiently handle standard chlorine gas cylinders. Standard size determined by the Chlorine Institute is 80-3/4" to 82-1/4" in length. Special low headroom modification is available.

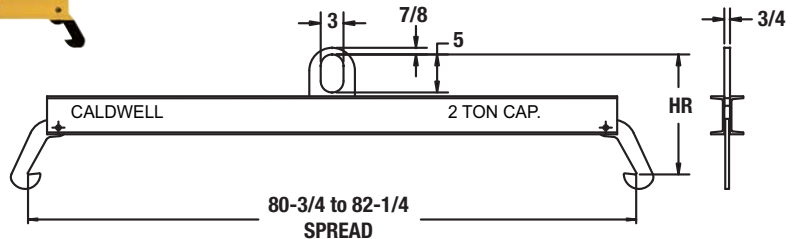

NOTE: All dimensions shown in inches.

**QUICKSHIP PROGRAM**

### SPECIFICATIONS

Model Number	Capacity (tons)	HR Headroom (in.)	Weight (lbs.)
28-2-80/82	2	16-1/2 - 15-1/2	105