

Pipe & Manhole Handling

Model MCL - Manhole Sleeve Lifter

PRODUCT FEATURES:

- Easily attaches to and releases from the load.
- Quick and efficient way to place cast manhole sleeves.
- Conforms to ASME B30.9 & B30.20

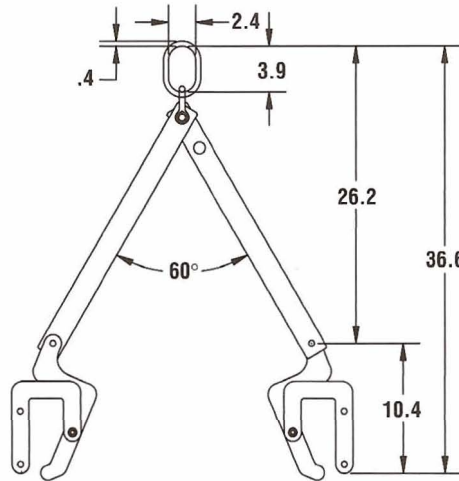

IN-STOCK PROGRAM



Optional 3-Leg Model

SPECIFICATIONS

Model Number	Description	Capacity (lbs.)	Wt. (lbs.)
MCL-1/2	2-Leg Version	1,000	24
MCL-3/4	2-18" Legs, 1-30" Leg With Shortener	1,500	26
MCL-C	Clamps Only	500	6

NOTE: Flange diameter range 12" - 30"
Consult factory for other frame configurations.

Operation



2-Leg Version

3-Leg Version